

\*- DIMENSIONS VARY FOR DOOR SIZE, GATE TYPE, SPEED, ETC. DIMENSIONS GIVEN ARE BASED ON 7'-8" INSIDE CAB.

SECTION A-A  
NOT TO SCALE

HOISTWAY PLAN



TRACTION FREIGHT  
ELEVATION & PLAN VIEW

CAPACITY 10,000 lbs. 100.TF.B.1E.14  
VERTICAL BI-PARTING

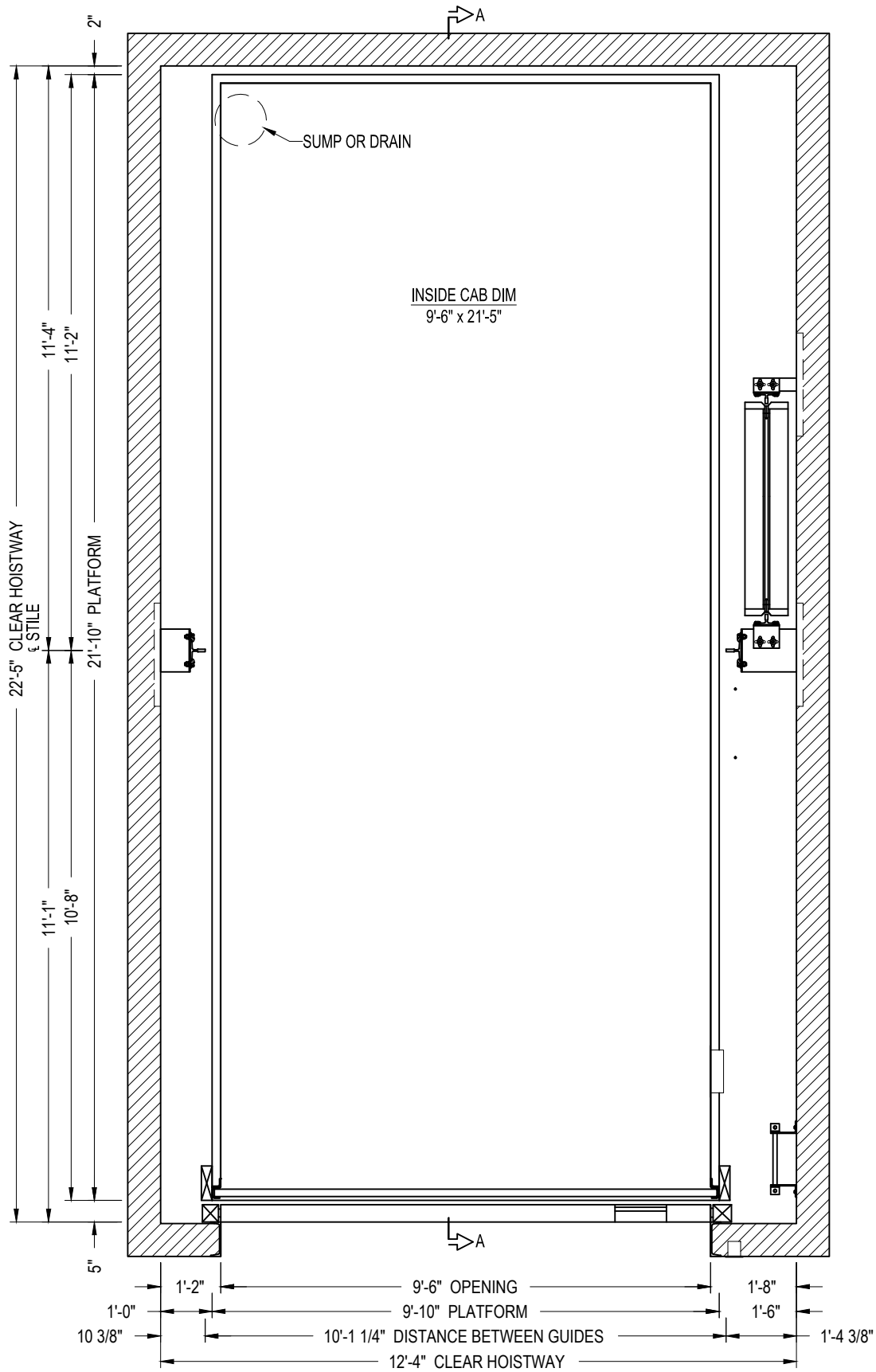

HOISTWAY PLAN



TRACTION FREIGHT

PLAN VIEW

CAPACITY 10,000 lbs.

100.TF.B.1E.14

VERTICAL BI-PARTING

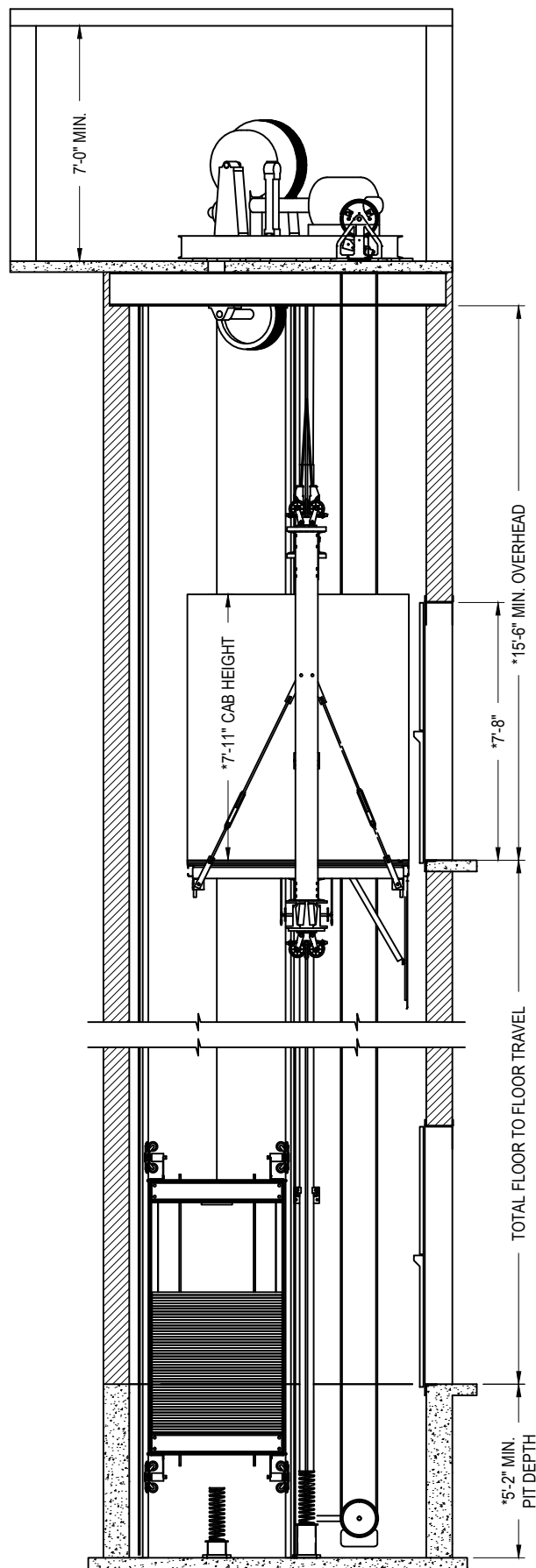

\*- DIMENSIONS VARY FOR DOOR SIZE,  
GATE TYPE, SPEED, ETC. DIMENSIONS  
GIVEN ARE BASED ON 7'-8" INSIDE CAB.

SECTION A-A  
NOT TO SCALE

TRACTION FREIGHT  
ELEVATION VIEW

CAPACITY 10,000 lbs. 100.TF.B.1E.14  
VERTICAL BI-PARTING

